

KC175GHT-2

High efficiency multicrystal photovoltaic module



EXAMPLES OF APPLICATION

- Grid-connected systems, for e.g.
 - Residential Solar Power Systems
 - Public and Industrial Solar Power Systems
- Solar power stations



CUTTING-EDGE TECHNOLOGY

Exhaustive research work, continuous further development of production processes and highly automated production enable polycrystalline Kyocera solar modules to attain an exceptional standard of quality and markedly high levels of efficiency.

The integrated Kyocera high-performance solar cells with a standard size of 15 cm x 15.5 cm achieve over 16 % efficiency, guaranteeing an extremely high annual yield of energy from the photovoltaic system.

To protect against the harshest weather conditions, the cells are embedded between a reinforced glass covering (hailstorm resistance complying with IEC 61215, tested by TÜV) and EVA foil, and are sealed with a PET foil backing. The laminate is set in a sturdy aluminum frame which is easy to assemble.

The back of the junction box is equipped with bypass diodes that eliminate the risk of the individual solar cells overheating (hot spot effect). Many series-connected photovoltaic modules can be easily wired using pre-assembled solar cables and multi-contact plugs.

Kyocera manufactures all the components at its own production sites – without buying in semi-finished products – to ensure consistently high product quality.

TUVdotCOM Service: Internet platform for tested quality and service
 TUVdotCom-ID: 0000007146
 IEC 61215 and Safety Class II
 Kyocera is ISO 9001 and ISO 14001 certified and registered.



**KYOCERA
SOLAR**

We care!

SPECIFICATIONS

in mm

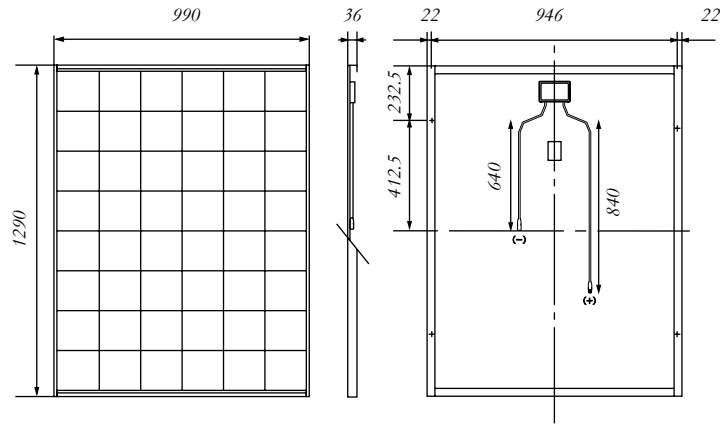

ELECTRICAL CHARACTERISTICS

Current-Voltage characteristics at various cell temperatures

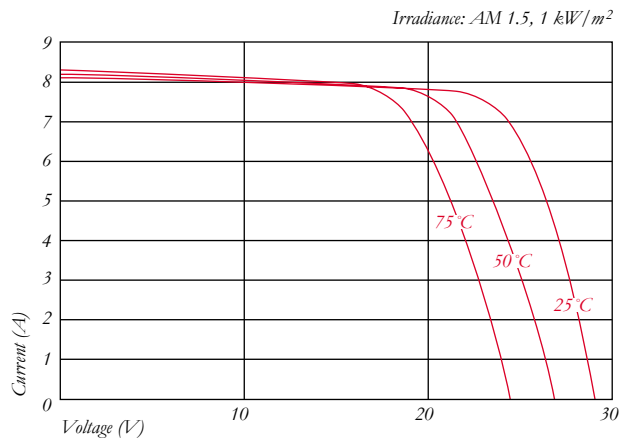

Current-Voltage characteristics at various irradiance levels

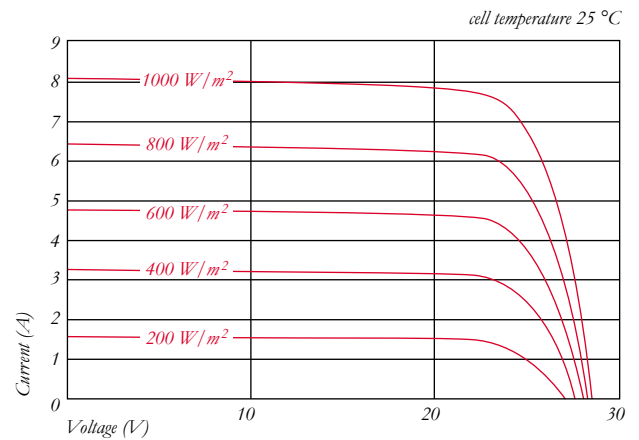

ELECTRICAL PERFORMANCE

PV module type KC175GHT-2

At 1000 W/m² (STC)*

Maximum Power	[W]	175
Maximum System Voltage	[V]	1000
Maximum Power Voltage	[V]	23.6
Maximum Power Current	[A]	7.42
Open Circuit Voltage (V _{OC})	[V]	29.2
Short Circuit Current (I _{SC})	[A]	8.09

At 800 W/m² (NOCT)**

Maximum Power	[W]	125
Maximum Power Voltage	[V]	20.9
Maximum Power Current	[A]	5.99
Open Circuit Voltage (V _{OC})	[V]	26.5
Short Circuit Current (I _{SC})	[A]	6.53

NOCT	[°C]	47
Power tolerance	[%]	+10 / -5
Temperature Coefficient of V _{OC}	[V/°C]	-1.09x10 ⁻¹
Temperature Coefficient of I _{SC}	[A/°C]	3.18x10 ⁻³
Reduction of efficiency (from 1000 W/m ² to 200 W/m ²)	[%]	5.1

DIMENSIONS

Length	[mm]	1290
Width	[mm]	990
Depth / incl. junction box	[mm]	36 / 36
Weight	[kg]	16,0
Cable	[mm]	(+)840/(-)640
Connection type		MC-PV3
Junction box	[mm]	113.6x76x9
IP Code		IP65

GENERAL INFORMATION

Performance guarantee	10*** / 20 years****
Warranty	2 years

CELLS

Number per module	48
Cell Technology	multicrystal
Cell Shape (rectangular)	[mm] 150x155
Cell Bonding	3 busbar

* Electrical values under standard test conditions (STC): irradiation of 1000 W/m², airmass AM 1.5 and cell temperature of 25 °C

** Electrical values under normal operating cell temperature (NOCT): irradiation of 800 W/m², airmass AM 1.5, wind speed of 1 m/s and ambient temperature of 20 °C

*** 10 years on 90% of the minimally specified power P under standard test conditions (STC).

**** 20 years on 80% of the minimally specified power P under standard test conditions (STC).

Your local Kyocera dealer:

**KYOCERA
SOLAR**

We care!

**KYOCERA Fin ceramics GmbH
Solar Division**
Fritz-Mueller-Str. 107
73730 Esslingen/Germany
Tel: +49 (0)711 939 34-999
Fax: +49 (0)711 939 34-950
Email: solar@kyocera.de
www.kyocerasolar.de